

The Kenmure mailbox standard is based on AASHTO Guidelines aimed at preventing serious injury or property damage and will be enforced on all new home construction AND mailbox replacement installations. Key elements of the standard include mailbox location, box weight/size, size & permanence of the post and its installation.

Recommended mailbox configuration:

USPS-approved, small or medium,
Black, metal or plastic mailbox

Bottom of mail box 42 inches above road surface

Asphalt Road Surface

Front edge of mailbox 8 to 12 inches from edge of road

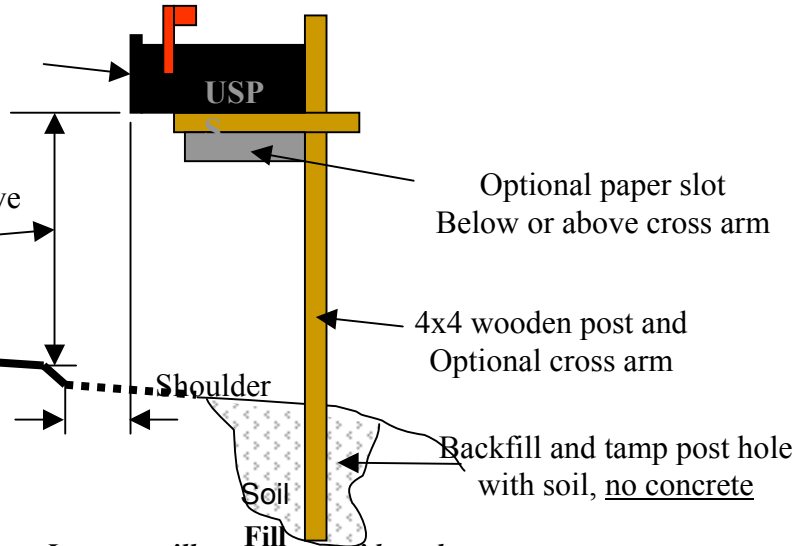

•Locate mailbox on same side as home

•If near driveway, install mailbox on “far” side of driveway in direction of route

•If a corner lot, install mailbox a minimum of 100 feet from intersection

Approval will be based on “substantial compliance” in meeting the safety intent of this standard. Non-conforming mailboxes must be corrected.

<u>Item</u>	<u>Recommendation</u>	<u>Substantial Compliance</u>	<u>Not Permitted</u>
Box	<ul style="list-style-type: none"> • Postmaster-Approved • Metal or plastic • Small Box • Color: Black 	<ul style="list-style-type: none"> • Minimum weight added in customizing Postmaster-Approved • Medium Box • Color: Earth Tone 	<ul style="list-style-type: none"> • Box not Postmaster-Approved • Excessive weight • Box larger than 22 x 8 x 11 • Bright or Pastel Colors
Post	4 by 4 wood	<ul style="list-style-type: none"> • 6 by 6 wood post - (NO 6 by 6 cross arm) • 4 by 4 extruded aluminum or plastic • 2 – 2 ½ inch diameter pipe 	<ul style="list-style-type: none"> • Wood post greater than 6 by 6 • Wood cross arm greater than 4 by 4 • Pipe post > 2 1/2 in. • Stone or masonry • Concrete base
Location	Front of box <u>OR</u> cross arm between 8 & 12 inches from road edge	Must comply	<u>Must comply</u>